

Ukupna masa: 162,27 kg

Napomena: Pozicije 8 i 9 treba očistiti nakon obrade.

Kom.	Naziv	Poz.	DIN/Br.nacrta	Matrijal	Sirova mjera	kg
2	Lim	1	HM-1002-20-001	1.0038 S235JRG2	5x860x716	38,4
1	Lim	2	HM-1002-20-002	1.0038 S235JRG2	12x680x760	48,7
2	Lim	3	HM-1002-20-003	1.0038 S235JRG2	10x650x535	24,8
2	Lim	4	HM-1002-20-004	1.0038 S235JRG2	Ø90x5	0,5
8	Lim	5	HM-1002-20-005	1.0038 S235JRG2	Ø60x5	0,9
2	Lim	6	HM-1002-20-006	1.0038 S235JRG2	5x680x561	16,5
2	Šipka	7	HM-1002-20-007	1.0038 S235JRG2	Ø30x25	0,1
2	Šipka	8	HM-1002-20-008	1.0038 S235JRG2	Ø40x35	0,3
2	Lim	9	HM-1002-20-009	1.0038 S235JRG2	5x860x460	20,0
2	Lim	10	HM-1002-20-010	1.0038 S235JRG2	5x85x669	4,5
2	L	11	HM-1002-20-011	1.0038 S235JRG2	730 lg	4,3
2	Lim	12	HM-1002-20-012	1.0038 S235JRG2	5x70x680	3,7
2	Lim	13	HM-1002-20-013	1.0038 S235JRG2	8x125x125	2,0

Mjerilo 1:1		VELEUČILIŠTE U KARLOVCU	
Naziv: Nosiva konstrukcija			
Broj crteža		HM-1002-20-000	
Datum: 16.5.2018		Izradio: H.Matusak	
Odobrio: H.Matusak		Lst: 1	
		Lstova: 2	

A (1:5)

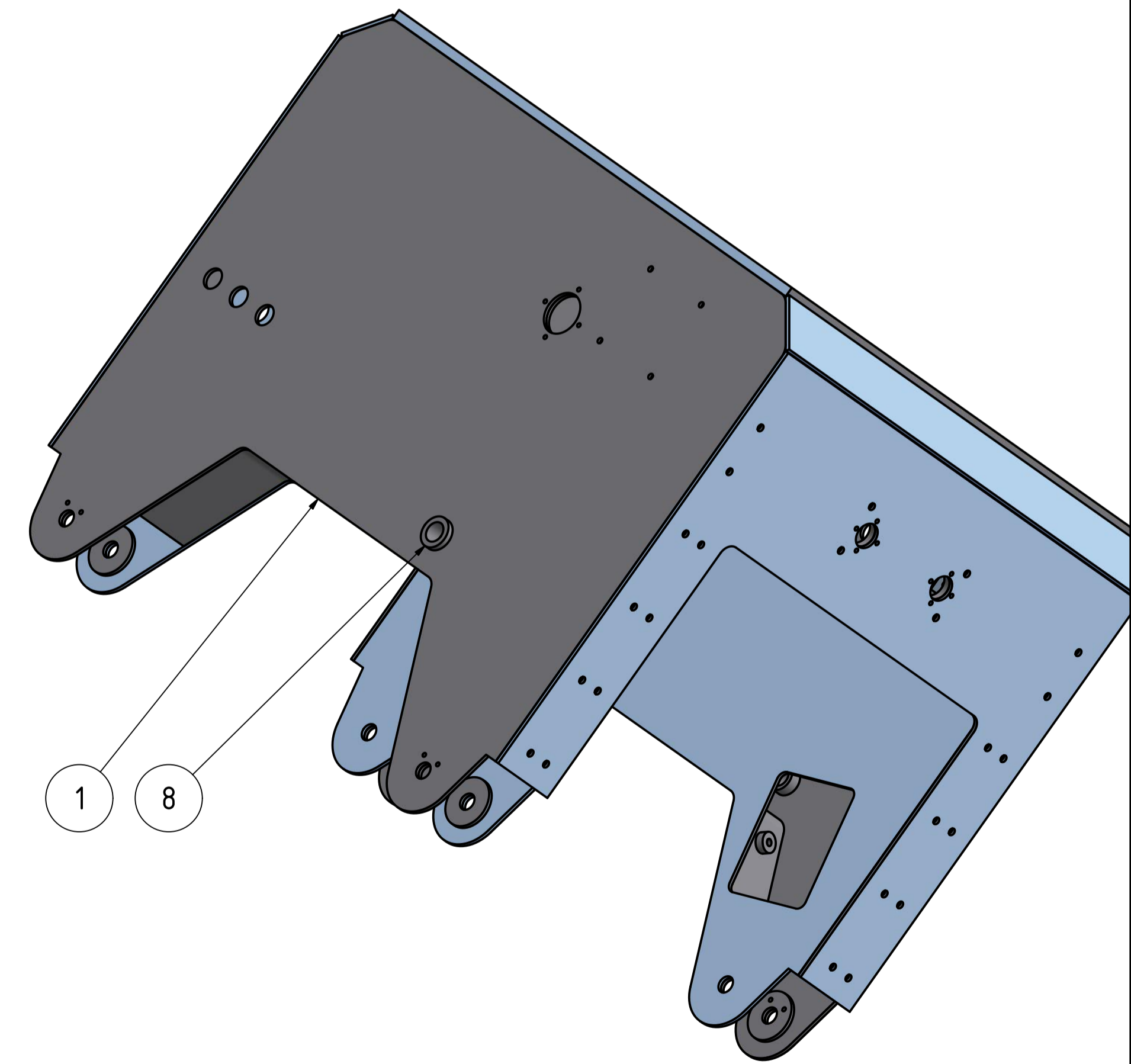
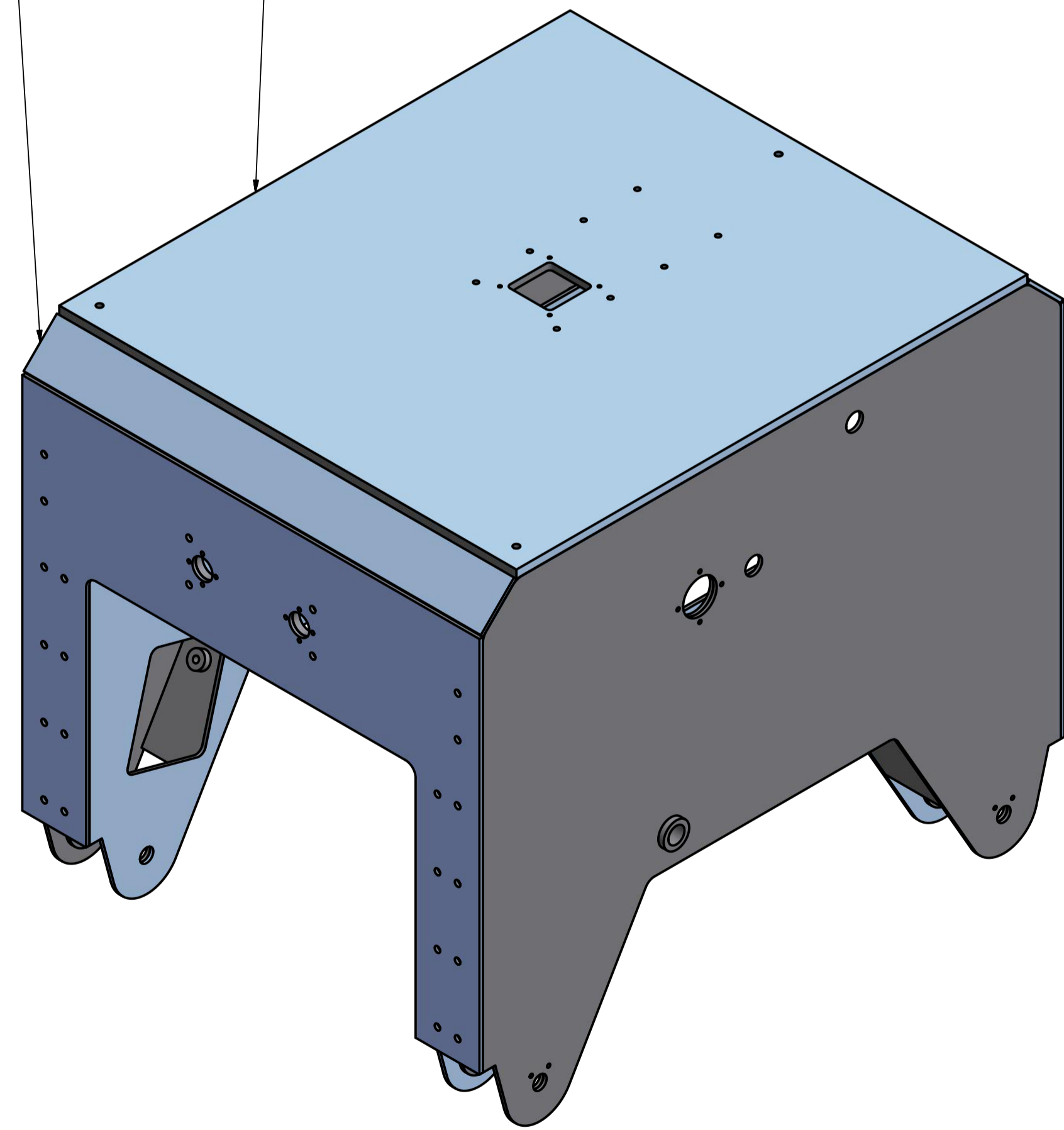
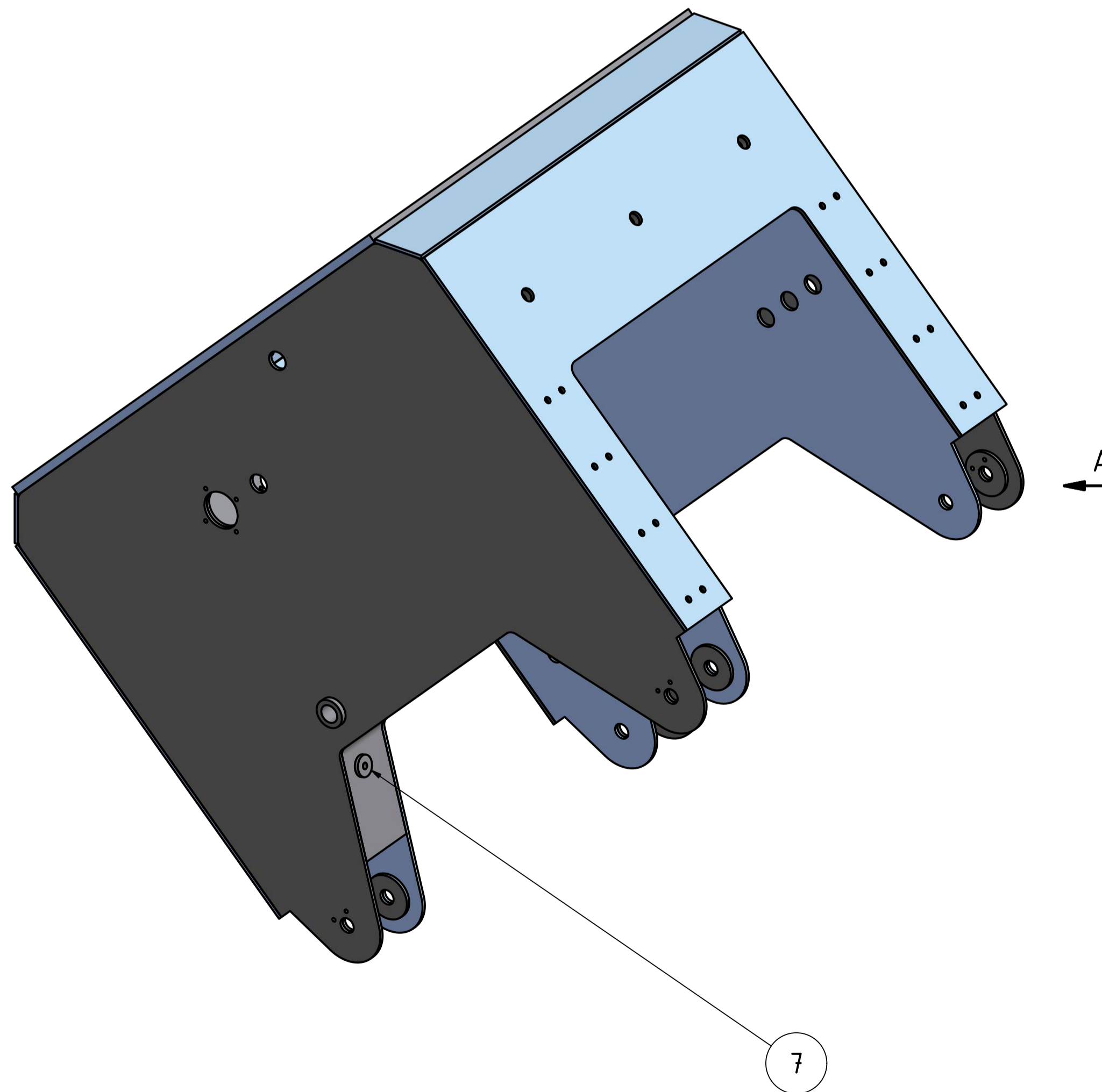
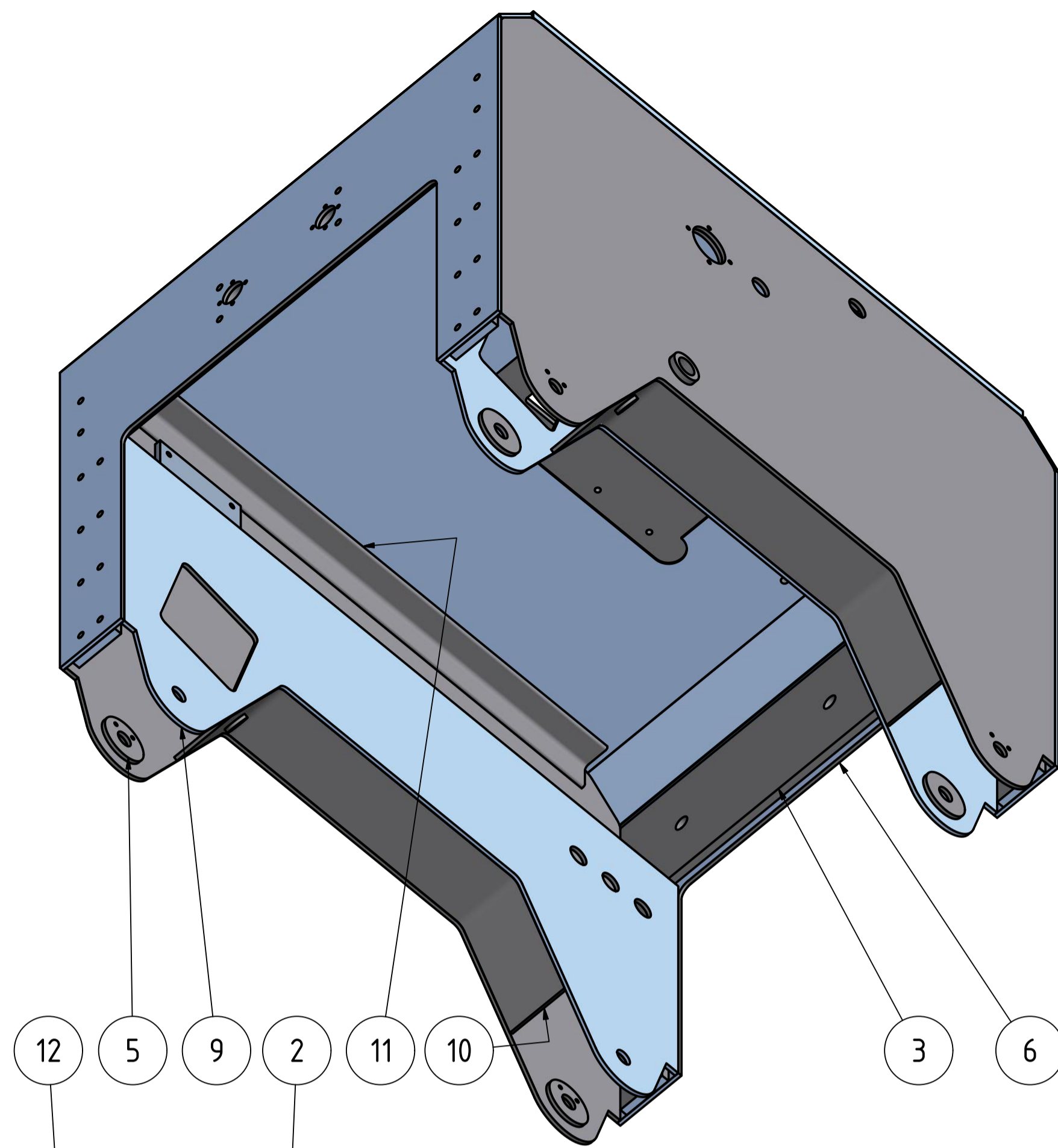
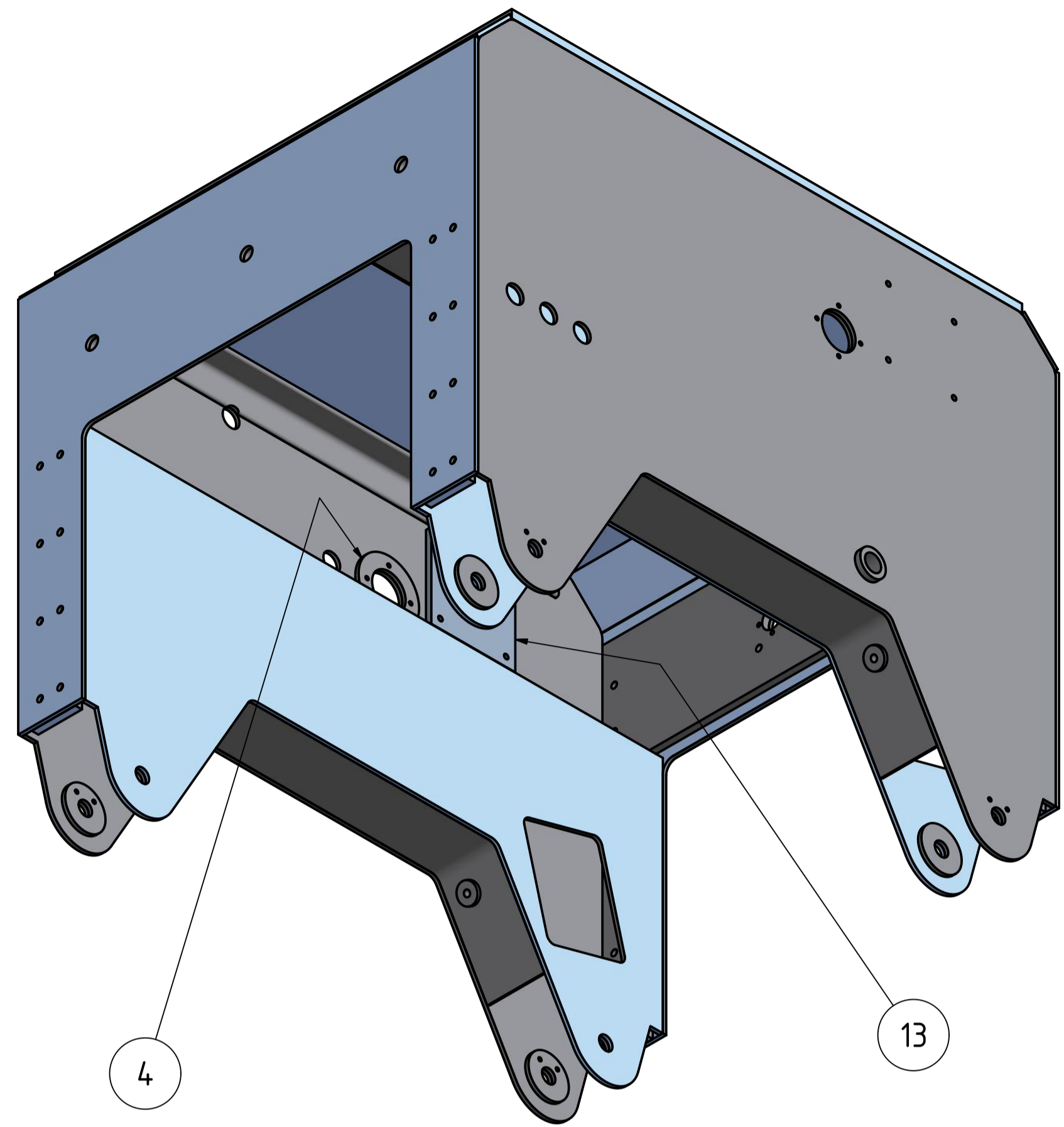

Kom.	Naziv	Poz.	DIN/Br.nacrta	Materijal	Sirova mjera	kg
				Mjerilo 1:5 1:1	VELEUČILIŠTE U KARLOVCU	
				Naziv Nosiva konstrukcija		
				Broj crteža		
				HM-1002-20-000		List: 2
						listova: 2
						A1