

Slika

Bogdan, David

Supplement / Prilog

Publication year / Godina izdavanja: **2016**

Permanent link / Trajna poveznica: <https://urn.nsk.hr/urn:nbn:hr:122:726567>

Rights / Prava: [In copyright](#)

Download date / Datum preuzimanja: **2022-12-01**



Repository / Repozitorij:

[University North Digital Repository](#)

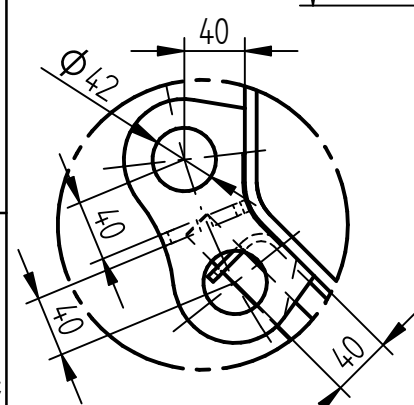
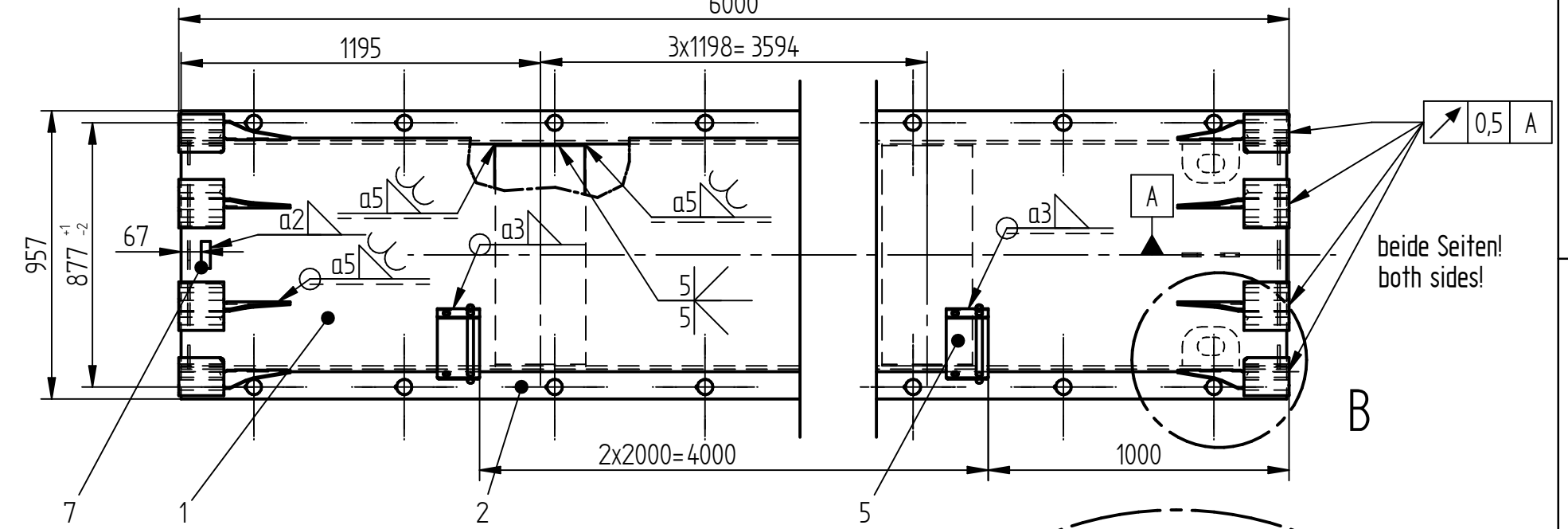
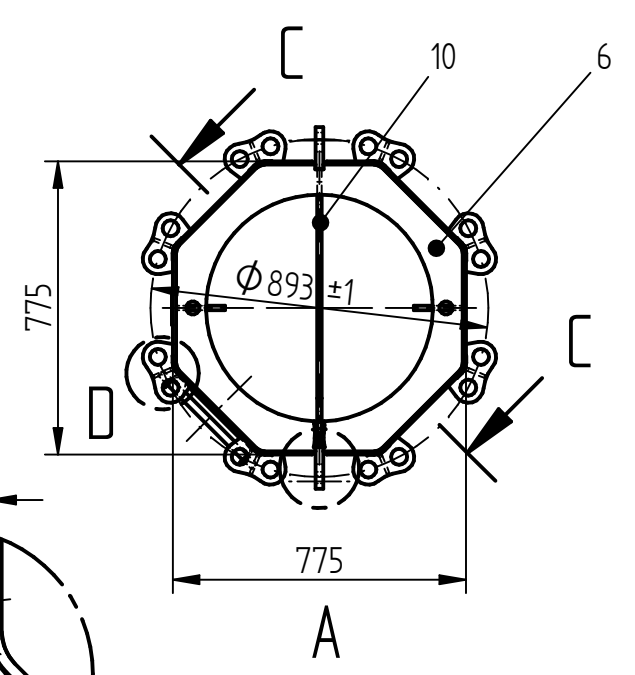

Detail D

Nähte mit PU-Spezial
(Art.-Nr. 10152800) abdichten/
seam sealed with
PU-Spezial
(Id.-No. 10152800)

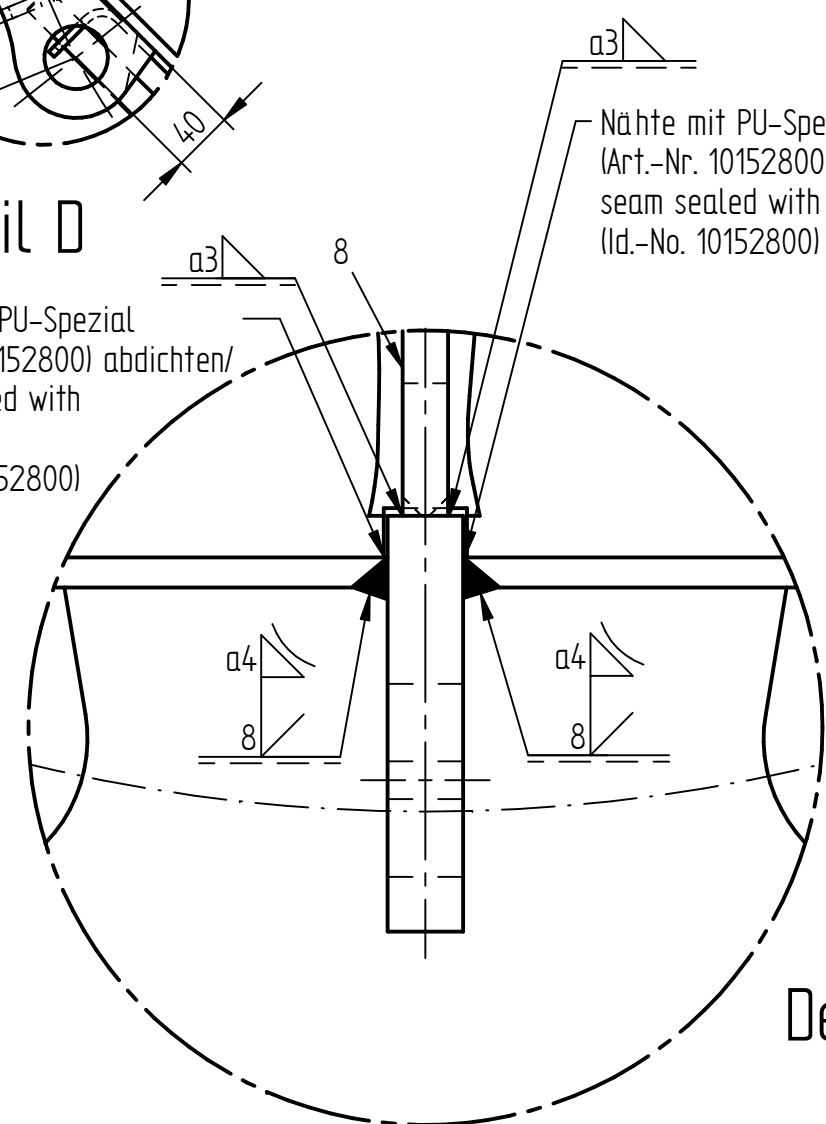

Detail A
1:2

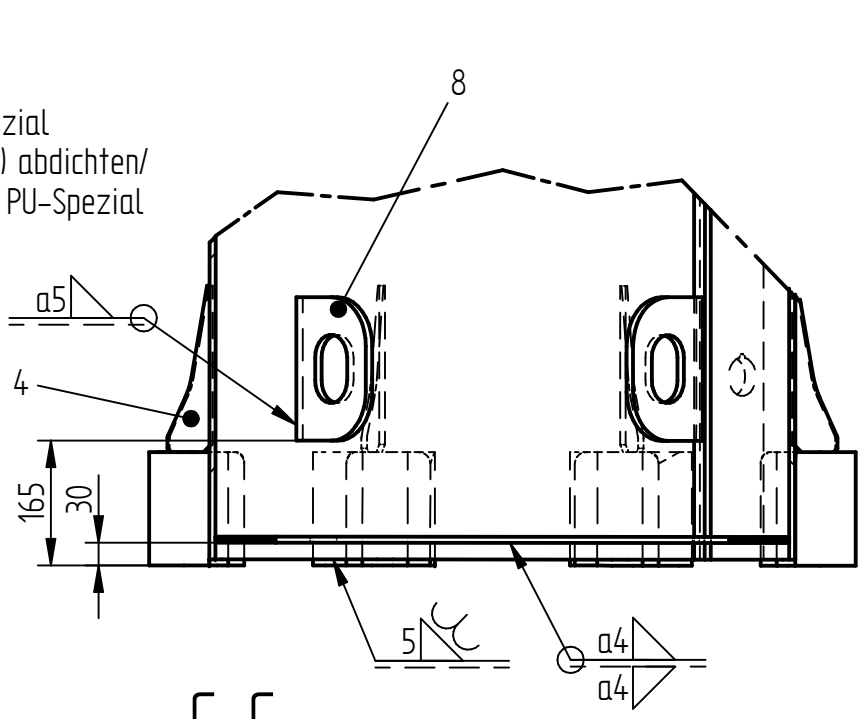

1:10

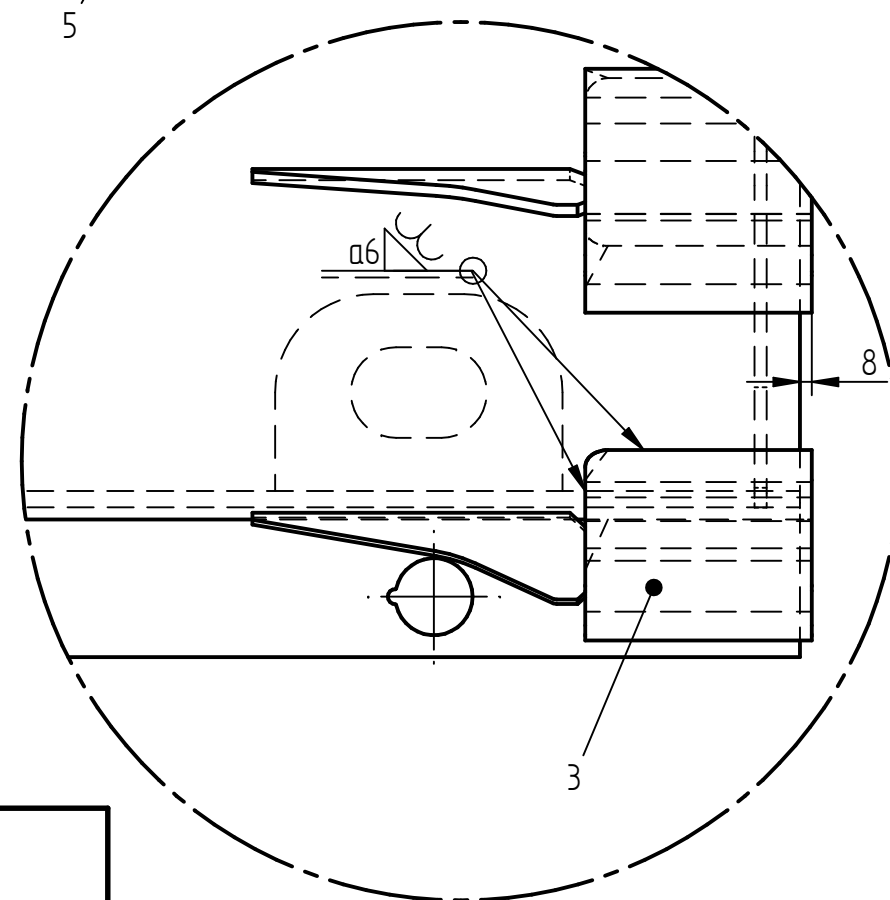

Detail B
1:5

Für die Fertigung gilt:
Applicable for the manufacture:
Bewertungsgruppe: B DIN EN 25817
Assessment group:
Schweißverfahren: MAGM / E
Weld process:
Zusatzwerkstoff: 72093 D 003
Filler metal:
Schutzgas: E 003
Shielding gas: G 001

Allgemeintoleranz siehe Werknorm 1.5 / General Tolerances WN-No.: 1.5

Schutzvermerk DIN 34-1-D Copyright reserved Schwing GmbH	Format / SIZE: A 3	Datum / DATE: 13.04.05	Name / NAME: J.Richter	Sicherheitsteil / SAFETY PART: S1	Benennung / NAME: Rohrmast 6 m	Dokumenteninfosatz-Nr. / DIS NO.: 1000041649		Material-Nr. / PART NO.: 10214678
	Ers. durch / REPL. BY:	Gezeichnet / DRAWN BY: 13.04.05	Geprüft / CHECKED BY: 17.10.2013	Gewicht / WEIGHT (kg): 1423,575	Maßstab / SCALE: 1:10	Rev. / REV: 08	Datum / DATE: 16.10.2013	Name / NAME: BSTREIER
	Ers. für / REPL. FOR:	Werkstoff / Werkstoff-Nr.: / MATERIAL / MATERIAL CODE:			Nicht abmessen / DO NOT SCALE	Blatt-Nr. / SHEET: 1 / 1		SCHWING
	Ung.-Datum/EXPIRY DATE:	- Assembly (siehe Stückliste, look at BOM)						